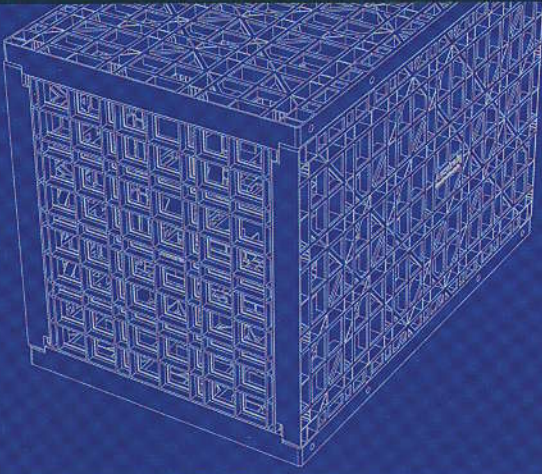

# septic leach drainage

AUSDRAIN sets the benchmark in septic leach drainage with the new EnviroModule™2 leach drain system. Ausdrain EnviroModules are manufactured in Australia from 100% recycled plastic.

EnviroModule™2	features	benefits
	<ul style="list-style-type: none"><li>• Sub-surface</li><li>• Modular</li><li>• High compressive strength</li><li>• High durability</li><li>• High void storage</li><li>• Open structure</li><li>• Lightweight</li><li>• Low maintenance</li><li>• Connectors</li><li>• Flat-pack form</li><li>• Slide and lock assembly</li><li>• 100% recycled</li></ul>	<ul style="list-style-type: none"><li>• More useable land area</li><li>• Design flexibility</li><li>• Trafficable</li><li>• Long life expectancy</li><li>• Cost-effective</li><li>• High flow rate</li><li>• Install by hand</li><li>• No cleaning required</li><li>• Makes installation easy</li><li>• Economical to transport</li><li>• Quick to assemble</li><li>• Environmentally friendly</li></ul>

The AUSDRAIN leach drain system is practical, cost-effective and easy to install. AUSDRAIN EnviroModules are lightweight, have an open structure providing high flow rates and are extremely robust enabling installation under trafficable areas such as car parks and driveways.

AUSDRAIN EnviroModules are delivered to site in flat-pack form saving on transportation costs. The modules feature a slide and lock assembly function that minimises the time and effort required to assemble each module.

Once assembled the modules are easily carried and lifted by hand into the trench. They are then placed end to end in a line and covered on the top, sides and ends with a recommended geotextile.

AUSDRAIN has further simplified the installation of leach drains with the 150mm pipe connector. The connector clips effortlessly to the top, side or end of the module, providing a positive and secure connection. The fabric can then be clamped to the connector. For smaller pipe diameters, reducers can be used.

The AUSDRAIN leach drain system has been approved by councils and regulatory authorities including the Department of Health in Western Australia and the Northern Territory.



# product specifications

## technical data

Length:	600mm
Width:	400mm
Height:	450mm
Weight:	4 - 5 kg
Void area:	95%
Storage volume:	105 litres
Unrestricted flow rate:	3510 litres/min

### Compressive strength

Standard duty module - 3 braces:	27.5 tonnes/m <sup>2</sup>
Extra duty module - 4 braces:	37.5 tonnes/m <sup>2</sup>

### Minimum cover recommended

Standard duty module:	400mm
Extra duty module:	400mm

### Maximum cover recommended

Standard duty module:	1200mm
Extra duty module:	1800mm

Service temperature:	-30°C + 120°C
Module material:	Recycled polypropylene

### Please note:

Compressive strength tests were conducted by a certified testing authority and represent the maximum strength in a controlled environment that replicates the case when soil is uniformly distributed under a short term static load. AUSDRAIN recommends a safety factor of 10 is applied to these results for actual design loads.

## installation procedure

- 1 Excavate trench allowing for 100mm to each side of the drain and 400mm above the drain to the surface. Level base using a 50-100mm layer of sand.
- 2 Assemble the modules using 4 sides and 3 braces for a non-trafficable landscaped area and 4 sides and 4 braces for a trafficable area. Please note that a suitable pavement consisting of road base and bitumen or a re-enforced concrete slab is required over the drain for trafficable situations.
- 3 Place the modules end to end along the length of the trench ensuring the 450mm side is in the upright position.
- 4 Attach the 150mm pipe connectors where required to the modules for inlet and inspection pipes.
- 5 Cover the top, sides and ends of the drain with the geotextile provided. If overlaps are required use a minimum of 300mm.
- 6 Cut an X in the fabric at each connector and seal the fabric to the connectors using adjustable clamps.
- 7 Backfill with coarse washed river sand to the sides of the drain and 100mm over the surface of the drain.
- 8 Place a minimum of 300mm of clean fill/topsoil over the sand layer and compact using machinery on tracks not exceeding 8 tonnes.

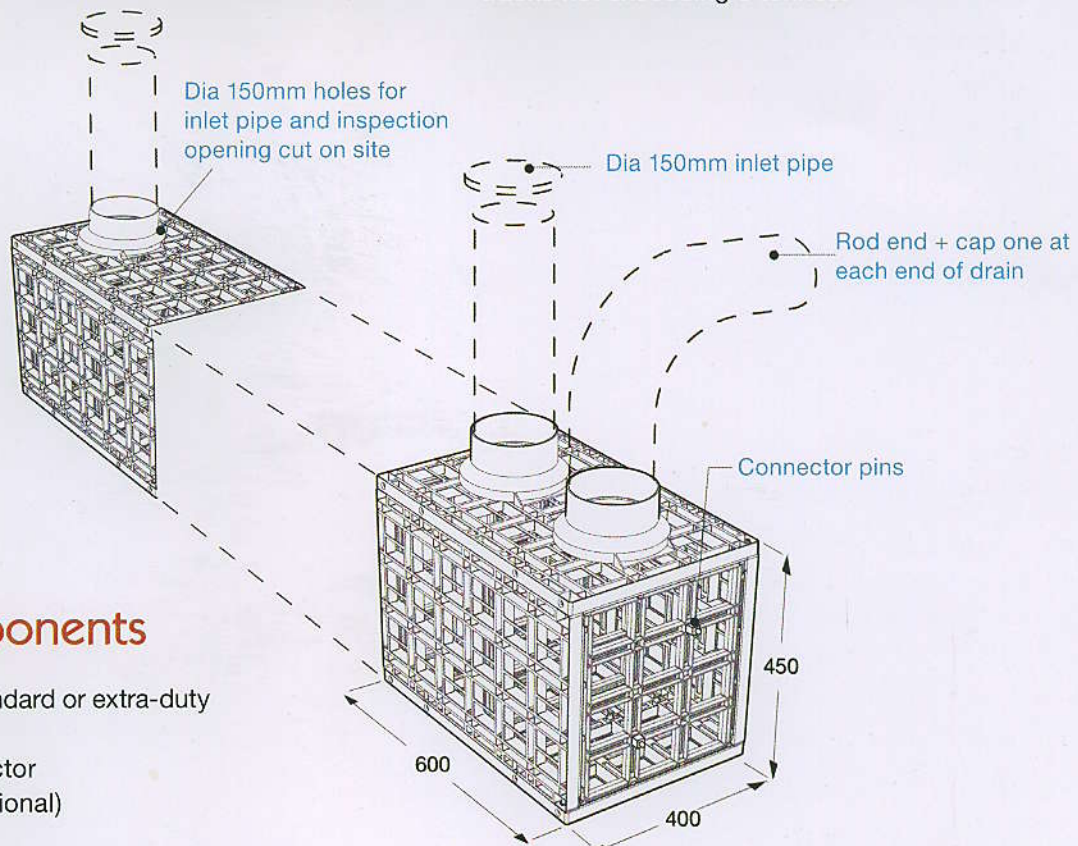

## system components

- EnviroModules – standard or extra-duty
- Geotextile fabric
- 150mm pipe connector
- Connector pins (optional)